

# ANSI CLAMP M12 - WITH EYE BOLT RATED 250A

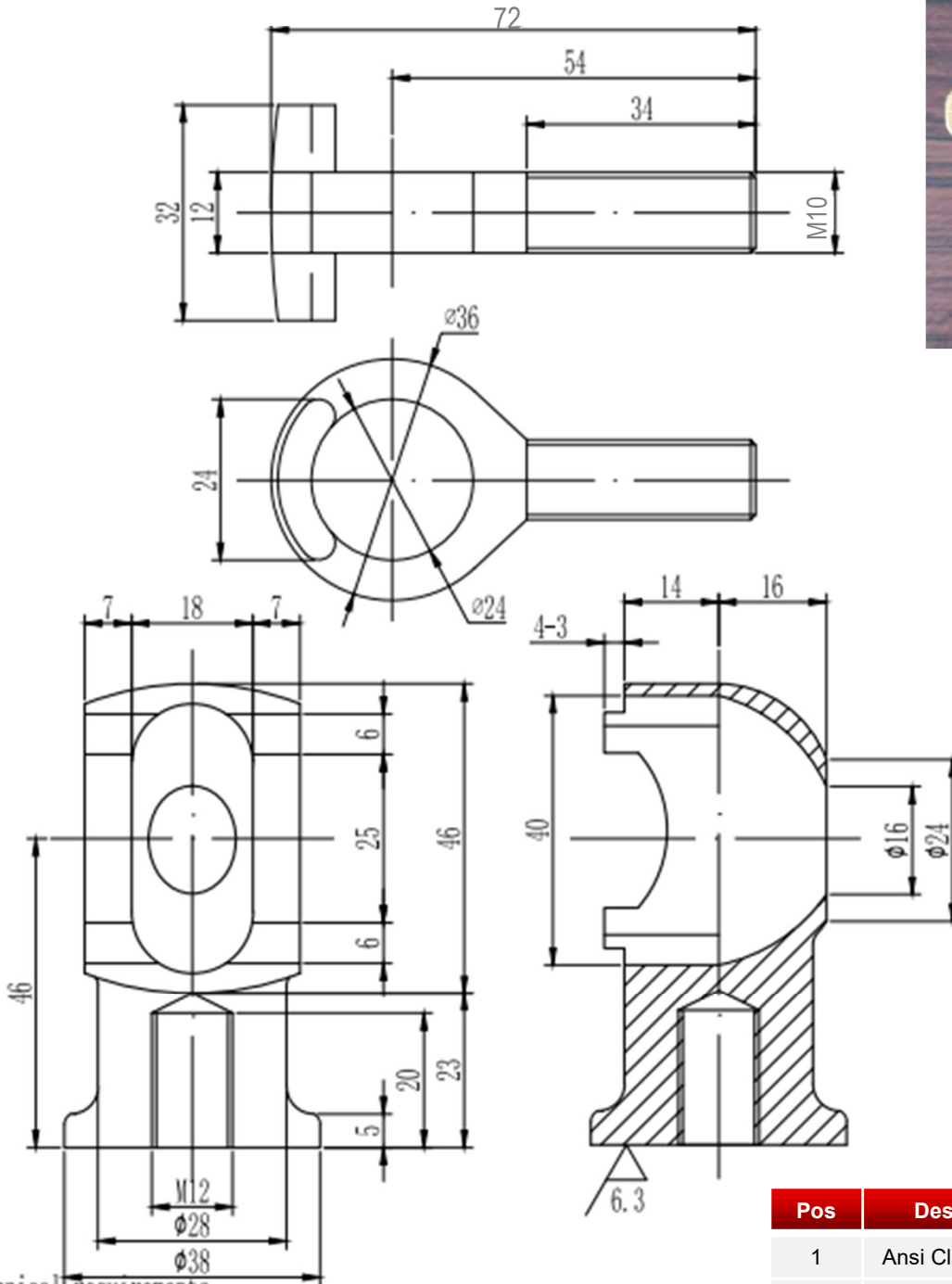

## Technical Requirements

- 1, all holes should be chamfered and deburring treatment
- 2, surface does not allow pores, sand holes, cracks
- 3, conductive surface does not allow scratches, protrusions, pits;
4. The thickness of tin coating shall not be less than 12µm.

Pos	Description	Material	Qty
1	Ansi Clamp M12	Brass	1
2	Eye Bolt M10	Brass	1
3	Spring Washer	Stainless Steel	1
4	Nut M10	Brass	1

# ANSI CLAMP M20 - WITH EYE BOLT RATED 630A

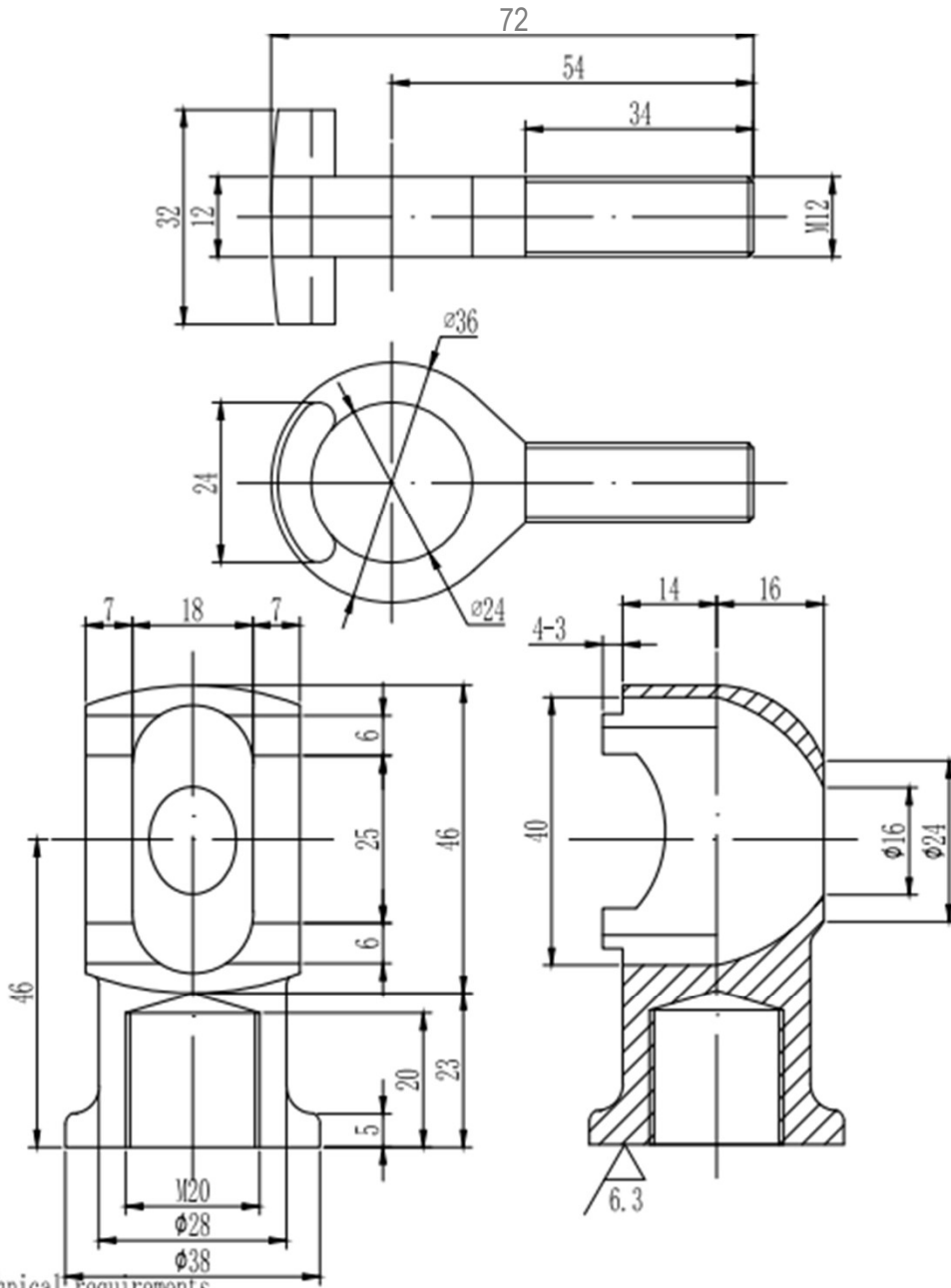

### Technical Requirements

all holes should be chamfered and deburring treatment  
surface does not allow pores, sand holes, cracks  
conductive surface does not allow scratches, protrusions, pits;  
The thickness of tin coating shall not be less than 12µm.

Pos	Description	Material	Qty
1	Ansi Clamp M20	Brass	1
2	Eye Bolt M12	Brass	1
3	Spring Washer	Stainless Steel	1
4	Nut M12	Brass	1