

SL.	DESCRIPTION
1	TOP COVER-ALUMINIUM
2	STAINLESS STEEL ARMOUR
3	GEL CONTAINER TUBE TRANSPARENT
4	SILICAGEL BLUE/ORANGE ROUND BALLS
5	OIL CUP TRANSPARENT
6	OIL WINDOW AND AIR INTAKE
7	BOTTOM COVER-ALUMINIUM
8	DESCRIPTION PLATE
9	FLANGE
10	SIEVE

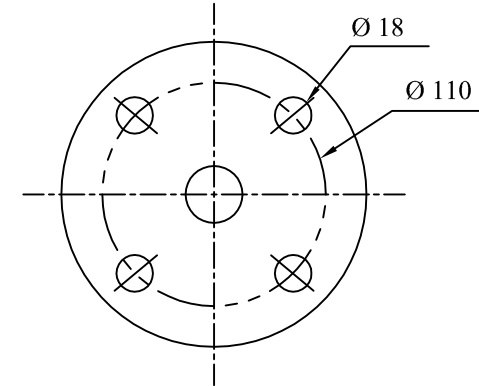

FLANGE CONNECTION

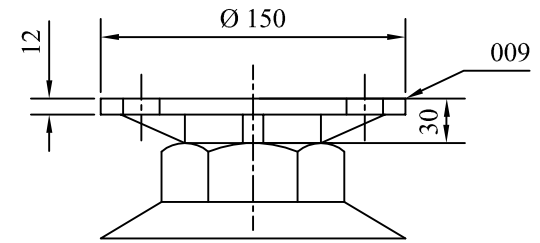
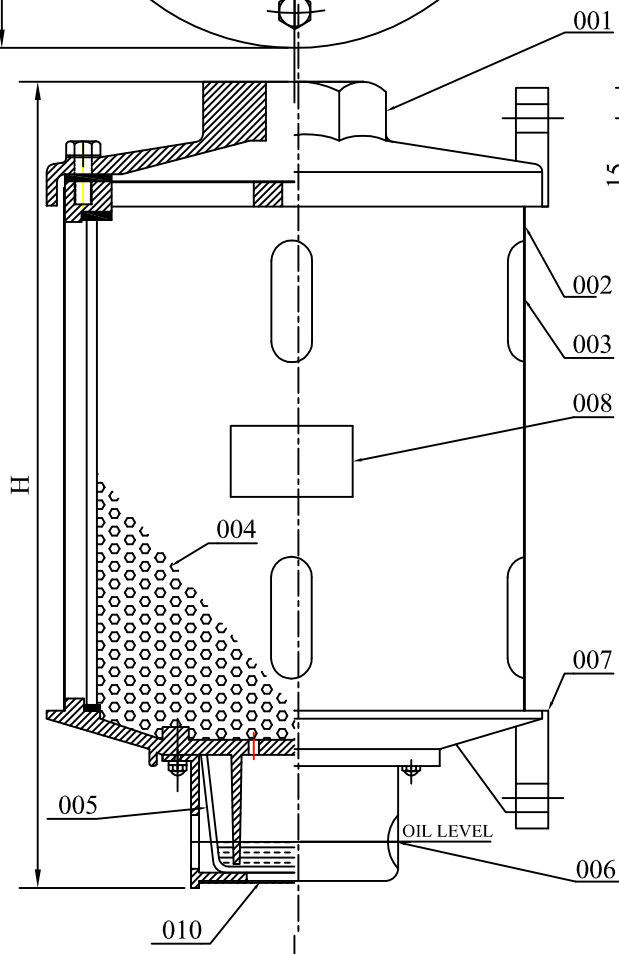
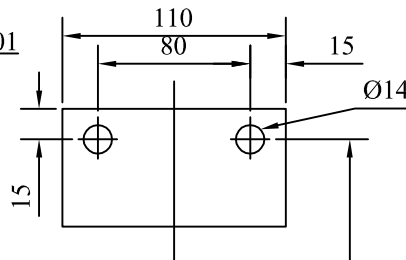

TYPE	TRFR. OIL KGS.	H	D	F	SILICAGEL	K	TOLER-ANCE	REFER-ENCE
					Kg			
PTS-50	17500	340	245	1 1/2" BSP	5.000	265	±5	VE-50
PTS-80	28000	490	245	1 1/2" BSP	8.000	415	±5	VE-80
PTS-100	35000	570	245	1 1/2" BSP	10.000	495	±5	VE-100
PTS-150	56000	870	245	1 1/2" BSP	15.000	795	±5	VE-150

NOTE:-
 1. FOR TAPPED CONNECTION DIMN. H-APPLICABLE.
 2. FOR FLANGED CONNECTION INCLUDE DIMN. 30 IN DIMN.-H.

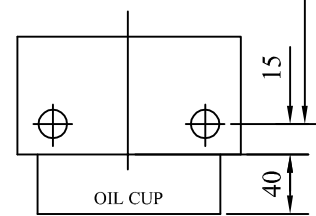

REV. 01
 IN DIM. TABLE FOR PTS-50 AND PTS-100, K WAS 310 MM AND 540 MM
 REV. 02
 VALUES OF K IS REVISED

		NAME	SING.	DATE
		J. S. TOMER		08. 06. 09
		P. SURI		12. 06. 09
		S. SURI		15. 06. 09
GRADE OF UN. TOL. DIM. C/W/F	SCALE	WEIGHT [KG]	REF. TO ASSY. NO.	ITEM NO
	NTS			NO
TITLE			DRAWING NO.	REV.
DEHYDRATING BREATHERS FOR POWER TRANSFORMER			PTS/5080	02
SHEET NO. 01		NO. OF SHEETS 01		