

This document is the exclusive property of METSON POWER. And shall not be used, copied or communicated to third parties without its prior authorization.

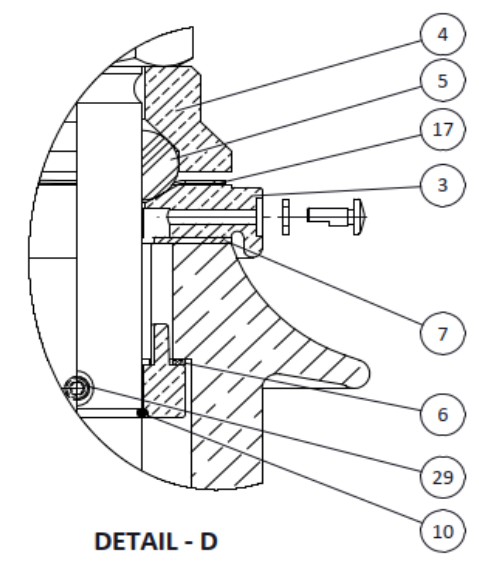

CREEPAGE DISTANCE= 295 mm

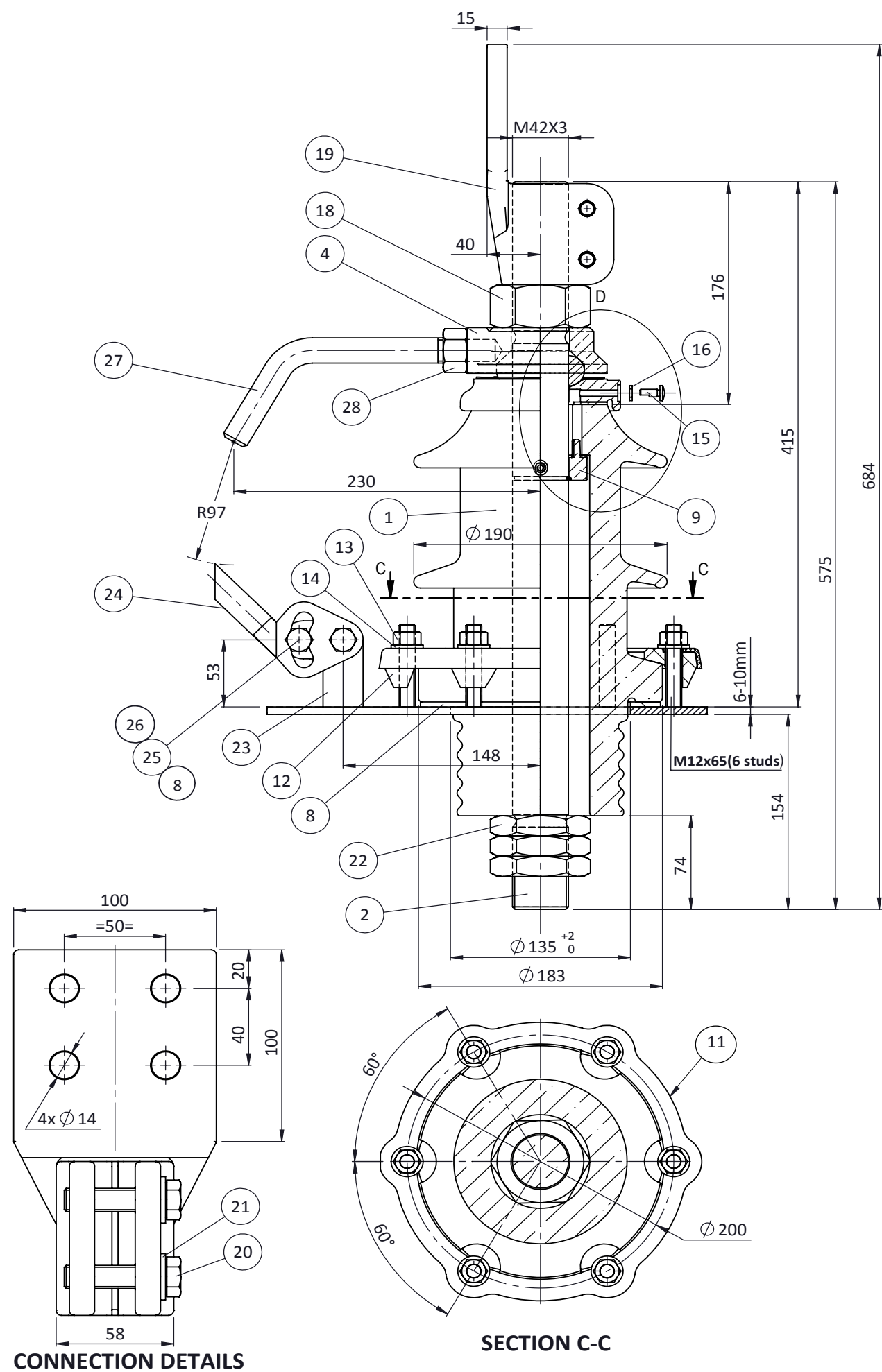
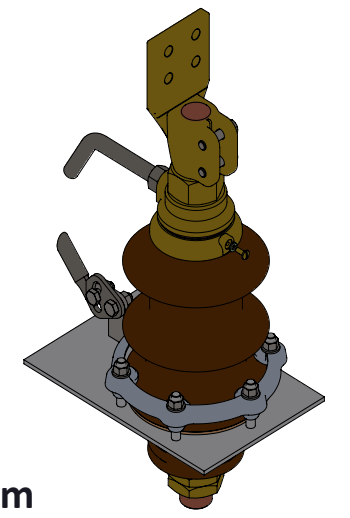

ITEM	QTY	DESCRIPTION	DIMENSION	MAT'L	ITEM CODE	REMARKS
29	2	SET SCREW M8x15		Steel		
28	1	NUT M20 ISO 4032		Steel		
27	1	TOP ARCING HORN		Steel		
26	2	SPRING WASHER M12 DIN 127		Steel		
25	2	BOLT M12x30 ISO 24017		Steel		
24	1	BOTTOM ARCING HORN		Steel		
23	1	"T" SUPPORT		Steel		
22	3	BRASS HALF NUT M42x3		Brass		
21	2	PLAIN WASHER M12 DIN 125		Stainless Steel		
20	2	BOLT M12x50 ISO 24017		Stainless Steel		
19	1	CONNECTION FLAG		Brass		
18	1	BRASS FULL NUT M42x3		Brass		
17	1	U-WASHER		Copper		
16	1	GASKET		Pressboard		
15	1	"R" BOLT		Brass		
14	6	PLAIN WASHER M12 DIN 125		Steel		
13	8	STEEL NUT M12		Steel		
12	6	ALU - PRESS BIT DIN 42538		Aluminum		
11	1	FIXING RING DIN 42538		Aluminum		
10	1	"S" RING		Copper		
9	1	PRESSING RING		Brass		
8	1	"N" GASKET 180x135x4		Cork Rubber		
7	1	"M" GASKET 100x50x2		Cork Rubber		
6	1	"O" GASKET 70x50x2		Pressboard		
5	1	"J" GASKET 66x42x24		NBR		
4	1	"F" CAP		Brass		
3	1	"E" CAP		Brass		
2	1	STEM		Copper		
1	1	TOP PORCELAIN		Ceramic Porcelain		

ITEM	QTY	DESCRIPTION	DIMENSION	MAT'L	ITEM CODE	REMARKS
00	13/07/21	RV	MA	MA	Original	
Rev	Date	Drw	Chk	App	Description	
General Tolerance Machining : ISO 2768 - Coarse				Surface Texture : ISO 1302	All dimension in millimetres unless otherwise stated	
IF IN DOUBT - PLEASE ASK !						
				Title		
				HV BUSHING 12kV/2000A		
				Description		Scale
				10NF 2000A		NTS
Metson Power SAN. VE TIC. A.S. Fatih sultan Mehmet Bulv.inonu Mah. No 412B Blok Daire 57, Yenimahalle, Ankara - TURKEY				Drawing No.	Sheet No.	Total Sheet
				ID_A0304100	1	1
						Size A3